



USER INSTRUCTIONS

LPS Series Heavy-Duty Actuators

FCD LFENIM0001-00 – 12/13

*Installation
Operation
Maintenance*

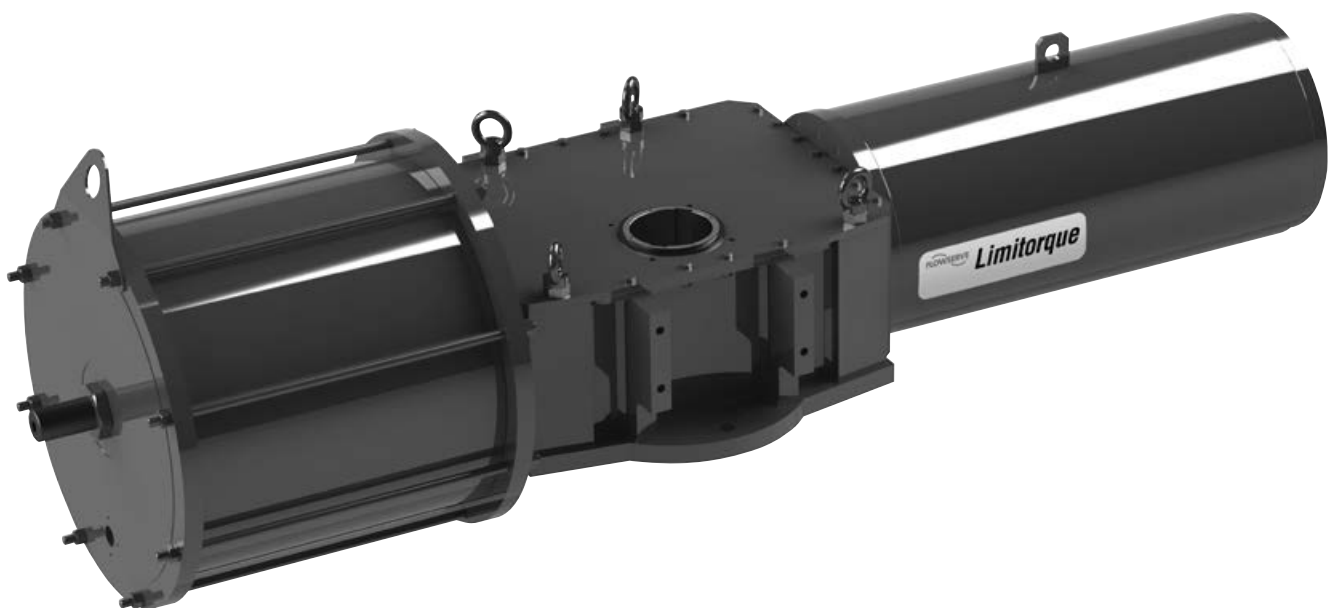

Experience In Motion

Contents

1	Standard Information	3
	Using Flowserve Valves, Actuators and Accessories Correctly	3
1.1	General Usage	3
1.2	Terms Concerning Safety	3
1.3	Protective Clothing	4
1.4	Qualified Personnel	4
1.5	Other Requirements for In-plant Installation	4
1.6	Spare Parts	4
1.7	Service/Repair	4
1.8	Storage	5
1.9	Valve and Actuator Variations	5
1.10	Unpacking	5
2	Installation Instructions	6
2.1	Valve and Actuator Check	6
2.2	Connection With Valve and Mounting Kit	6
2.3	Travel-stop Bolts and Accessories	7
2.4	Pneumatic Supply Fluids	7
2.5	Initial Operation	7
3	Maintenance Instructions	8
3.1	General Disassembly Instructions	8
3.2	Spring Container Maintenance	8
3.3	Pneumatic Cylinder Maintenance	10
3.4	Torque Module Maintenance	12
4	Field Conversion	13
	Field Conversion From Fail CW to Fail CCW or Vice Versa (for Spring Return Actuators)	13
5	Disposal of Decommissioned Actuators	16

Figures

Figure 1 – Spring Container Configurations	9
Figure 2 – Model Selection Table	15
Figure 3 – Single Acting Actuator Weight Table	17
Figure 4 – Double Acting Actuator Weight Table	17
Figure 5 – Single Acting Actuator Exploded View	18
Figure 6 – Double Acting Actuator Exploded View	19

1

Standard Information

Using Flowserve Valves, Actuators and Accessories Correctly

1.1 General Usage

The following instructions are designed to assist in unpacking, installing and performing maintenance as required on Flowserve products. Product users and maintenance personnel should thoroughly review this bulletin prior to installing, operating or performing any maintenance.

In most cases Flowserve actuators and accessories are designed for specific applications with regard to medium, pressure and temperature. For this reason they should not be used in other applications without first contacting the manufacturer.

1.2 Terms Concerning Safety

The safety terms DANGER, WARNING, CAUTION and NOTE are used in these instructions to highlight particular dangers and/or to provide additional information on aspects that may not be readily apparent.

 **DANGER:** indicates that death, severe personal injury and/or substantial property damage will occur if proper precautions are not taken.

 **WARNING:** indicates that death, severe personal injury and/or substantial property damage can occur if proper precautions are not taken.

 **CAUTION:** indicates that minor personal injury and/or property damage can occur if proper precautions are not taken.

NOTE: indicates and provides additional technical information, which may not be very obvious, even to qualified personnel.

Compliance with other, not particularly emphasized notes, with regard to transport, assembly, operation and maintenance and with regard to technical documentation (e.g., in the operating instruction, product documentation or on the product itself) is essential, in order to avoid faults, which in themselves might directly or indirectly cause severe personal injury or property damage.

1.3 Protective Clothing

Flowserve products are often used in problematic applications (e.g., extremely high pressures, dangerous, toxic or corrosive media). When performing service, inspection or repair operations, always ensure that the valve and actuator are depressurized and that the valve has been cleaned and is free from harmful substances. In such cases pay particular attention to personal protection (protective clothing, gloves, glasses, etc.).

1.4 Qualified Personnel

Qualified personnel are people who, because of their training, experience, instruction and their knowledge of relevant standards, specifications, accident prevention regulations and operating conditions, have been authorized by those responsible for the safety of the plant to perform the necessary work and who can recognize and avoid possible dangers.

1.5 Other Requirements for In-plant Installation

- Pipelines must be correctly aligned to ensure that the valve is not fitted under tension.
- Limatorque can provide fire protection systems. If not expressly agreed, fire protection must be provided by the user.

1.6 Spare Parts

Use only Flowserve original spare parts. Flowserve cannot accept responsibility for any damages that occur from using spare parts or fastening materials from other manufacturers. If Flowserve products (especially sealing materials) have been in storage for long periods, check these for corrosion or deterioration before using these products.

1.7 Service/Repair

To avoid possible injury to personnel or damage to products, safety terms must be strictly adhered to. Modifying this product, substituting non-factory parts, or using maintenance procedures other than as outlined in this instruction could drastically affect performance and be hazardous to personnel and equipment, and may void existing warranties.

Between actuator and valve there are moving parts. To avoid injury, Flowserve provides pinch-point-protection in the form of cover plates, especially where side-mounted positioners are fitted. These protections are according to Machine Directive 2006/42/EC recommendations. If these plates are removed for inspection, service or repair special attention is required. After completing work the cover plates must be refitted.

Apart from the operating instructions and the obligatory accident prevention directives valid in the country of use, all recognized regulations for safety and good engineering practices must be followed.

- ▲ **WARNING!** Before products are returned to Flowserve for repair or service Flowserve must be provided with a certificate which confirms that the product has been decontaminated and is clean. Flowserve will not accept deliveries if a certificate has not been provided (a form can be obtained from Flowserve).

1.8 Storage

In many cases Flowserve products are manufactured from stainless steel. Products not manufactured from stainless steel are typically provided with an epoxy resin coating or with other painting systems as agreed with the customer. This means that Flowserve products are well protected from corrosion. Nevertheless, in order to maintain the equipment in working order with a good exterior finish until the actuator is installed in the plant, it is necessary to follow a few rules during the storage period:

- Flowserve products must be stored adequately in a clean, dry environment.
- Ensure that plastic caps are fitted to protect the pneumatic connections and the cable entries, to prevent the ingress of foreign materials. These caps should not be removed until the product is actually mounted into the system.
- If the storage is outdoors, or if long-term storage is necessary, the plastic protection plugs must be replaced with metal plugs, because the plastic plugs are not weatherproof, whereas the metal ones guarantee weatherproof protection.
- The actuator must be placed on a wooden pallet, in order to not damage the coupling base and avoid the other surfaces resting on the ground.

In case of long-term storage, additionally perform the following measures:

- Coat the coupling parts (spool piece base, flanges, bushings, joints) with protective oil or grease.
- If possible, blank off the spool piece base flange with a protection disk.
- Provide a tarpaulin cover or some other means of protection, especially if the storage is outdoors.
- It is important to periodically operate the actuator with filtered, dehydrated and lubricated air while in storage.

1.9 Valve and Actuator Variations

These instructions cannot claim to cover all details of all possible product variations, nor can they provide information for every possible example of installation, operation or maintenance. This means that the instructions normally include only the directions to be followed by qualified personnel where the product is being used for its defined purpose. If there are any uncertainties in this respect particularly in the event of missing product-related information, clarification must be obtained via the appropriate Flowserve sales office.

1.10 Unpacking

- Each delivery includes a packing slip. When unpacking, check all delivered actuators and accessories using this packing slip.
- Report transportation damage to the carrier immediately.
- In case of discrepancies, contact your nearest Flowserve location.
- If necessary, retouch minor damage to the paint coating which may have occurred during transport or storage.

NOTE: When the actuator has ATEX or SIL requirements, ensure that the “LPS Series Safety Manual” (Functional Safety and SIL Certification) and “LPS Series Safety Extract and Instruction Manual” (Explosive Atmosphere Equipment and ATEX Certification) accompany this manual and are referred to for equipment usage.

2 Installation Instructions

The LPS Series is a fully modular design, scotch yoke actuator; with torque range up to ~250 000 Nm (up to 184 000 ft-lbs), with a mounting base in compliance with ISO 5211 and the Technical Bulletin (LFENTB0001-00). It may also be customized, if required.

Unlike previous Flowserve scotch yoke actuators, the LPS series Spring Return Actuators use Push-to-Compress spring design.

▲ WARNING! Actuator operation/pressure limitations must be in accordance with Technical Bulletin (LFENTB0001-00).

2.1 Valve and Actuator Check

☠ DANGER: Before installation check the order-no., serial-no. and/or the tag-no. to ensure that the valve/actuator is correct for the intended application.

Prior to assembly, manually open and close valve (if possible), to ensure freedom of operation. Be sure valve and Limitorque actuator rotate in the same direction and are in the same position (i.e., valve closed, actuator closed). The assembly position of the actuator, with reference to the valve, has to be in accordance with the plant requirements (actuator axis parallel or perpendicular to the pipeline axis).

2.2 Connection With Valve and Mounting Kit

The LPS actuator is usually supplied with the spool piece already assembled. To assemble the actuator onto the valve, perform the following steps:

- Check the mounting surfaces, the stem adaptor and the spool piece to assure proper fit. Clean the flanges of the valve and spool piece to remove oils and greases since the torque is transmitted by friction. Also, remove any rust that may have occurred during storage.
- Secure the valve in the closed/open position, if possible, with the stem vertical. Lubricate the valve stem in order to ease the assembly. Place the stem adaptor on the valve stem.
- Lift the actuator by the special lift points (eyebolts), using a proper lifting system. Position the actuator over the valve and lower to engage the stem adaptor to the actuator bore. Continue to lower until the spool piece sits on valve mounting surface. This coupling has to take place without force and only with the weight of the actuator. The mounting bolts (or studs) of the valve should easily fit into the bolt holes of the spool piece without any binding. If needed, turn or stroke the actuator a few degrees and/or adjust the actuator travel-stops.
- The mounting nuts (or bolts) connecting the base of the spool piece to the valve flange must be evenly tightened according to Flowserve tables.

NOTE: In some cases, the coupling between valve and actuator can be direct, without the need of a spool piece. In these cases, Flowserve can provide an intermediate adaptor flange (fitted under the actuator base) and a special bushing to be inserted into the yoke bore.

▲ CAUTION! Lifting bolt holes/devices on the actuator are for lifting the actuator modules only, with eye bolts, not the complete valve and actuator assembly.

2.3 Travel-stop Bolts and Accessories

All actuated valves require accurate travel-stop adjustments at both ends of the stroke to obtain optimum performance and valve seat life. Adjust the travel-stop bolts of the actuator for the proper open and close valve positions, per valve manufacturer's recommendations.

The LPS actuators have travel-stop adjustments in both the clockwise and counter-clockwise directions. The +/- 5-degree adjustment feature provides shaft rotation from 80 to 100 degrees overall.

The adjustment of the travel-stops is performed in accordance with the following steps. Refer to Figure 5.

Pneumatic cylinder stop (28): Loosen the seal nut (62) with a proper wrench. Screw or unscrew the stop (28), using a proper Allen key, while keeping the seal nut stationary. Tighten the seal nut.

Spring container stop (45): Remove the spring container end cover (49) after unscrewing the hex screws (50). Screw or unscrew the stopper (45) to the desired position, using a proper Allen key. Replace the end cover and tighten the hex screws.

Pneumatically stroke the actuator several times to assure proper operation. The stem adaptor should not bind during operation. If the actuator is equipped with a switch, positioner or other accessories, adjust them at this time.

2.4 Pneumatic Supply Fluids

To prolong actuator life use only clean, dry pneumatic supply fluids. Lubricated fluids are not required; however, they are recommended, particularly for high cycle applications. Do not use lubricated fluids with positioners, as they may damage the positioner.

2.5 Initial Operation

Before initial operation of the actuator, perform the following checks:

- Check that all electrical supply, control and signal lines are properly connected, by following the dedicated customer procedures.
- Check that the pressure and quality of the supply fluids are as prescribed.
- Check that the required remote signals are correct and that the control unit with all its components works properly.
- Check the absence of leaks in the pneumatic connections. If necessary, tighten the pipe fittings.

3 Maintenance Instructions

LPS Series actuators are designed to offer the greatest ease of operation during assembly, disassembly and maintenance. The maintenance and disassembly do not require special equipment, or special or large wrenches. Furthermore the joints among the moving parts of the actuator are made exclusively through pins and not using bolts to be tightened with specific torques.

LPS actuators do not need maintenance for long periods, even if they are working in severe conditions. However, if the actuator operation happens infrequently, it is recommended to periodically check the actuator, performing the following steps:

- In the plants where it is possible, carry out a few opening and closing operations, involving all the control unit components, checking that the actuator operates correctly and within the required stroke times.
- Check that all the signals (pneumatic and electric) arriving at the actuator are correct and that the supply fluid pressure is within the required range. Check for the absence of leaks in the pneumatic connections. If necessary, tighten the pipe fittings.
- Check the paint coating. If some areas are damaged due to accidental events, retouch them according to the painting specifications.

In case of scheduled preventive maintenance, or following accidental events, refer to the following maintenance instructions regarding the three main actuator components (spring container, pneumatic cylinder and center body).

3.1 General Disassembly Instructions

- 3.1.1 Disconnect all air and electrical supplies from actuator;
- 3.1.2 If removal of the actuator from the valve is necessary, before dismounting the actuator remove all accessories from actuator;
- 3.1.3 The reference drawings for the instructions reported in the following paragraphs are the exploded views of single acting and double acting actuators, included as Figures 5 and 6.

3.2 Spring Container Maintenance

The spring container does not require maintenance. The lubricating of internal parts is carried out during the assembly and is not necessary during the normal life of the actuator. The substitution of the spring container is not expected over the entire actuator life. However, accidental events may result in damage to this component. In these cases, proceed as described in the following steps.

The spring container is a single welded module. In case of damage, the whole container must be disassembled from the actuator and replaced with a new one equal to the original.

The removal of the spring container from the actuator has to be performed through the following steps. The reference drawing is Figure 5.

▲ WARNING: Ensure that the pneumatic connection ports of the cylinder are disconnected. Also make sure that all pneumatic supplies to the control unit and all power supplies are disconnected. Finally, make sure that the actuator is in fail position, i.e., that it is not locked in a position with the spring compressed by means of locking devices.

Figure 1 – Spring Container Configurations

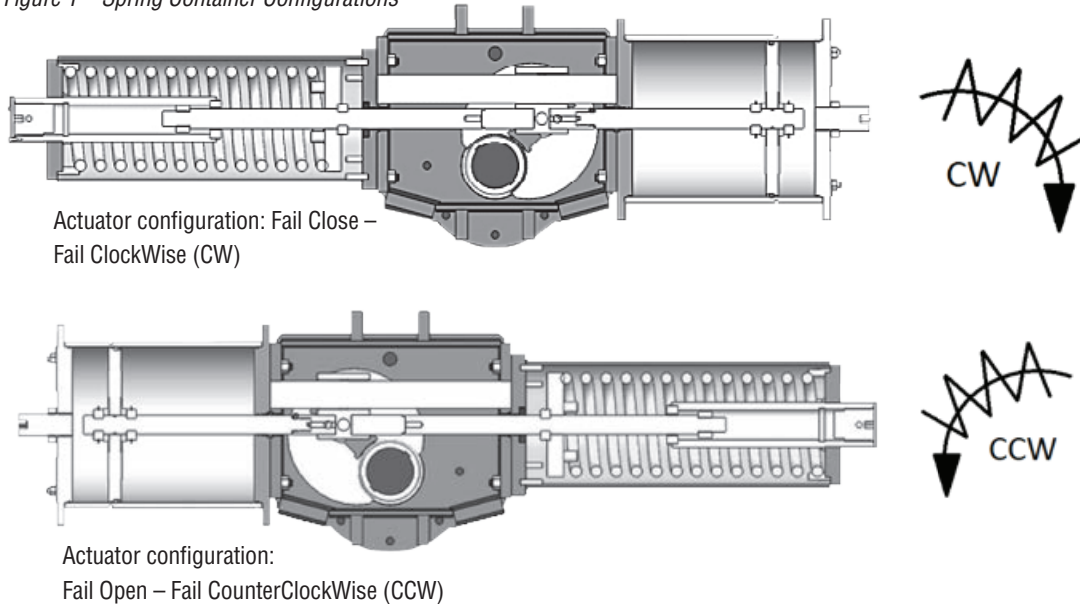

- 3.2.1 Unscrew and remove the travel-stop of the pneumatic cylinder (28). For removing the stop, refer to paragraph 2.3. If necessary, feed the pneumatic cylinder from the port on the head flange (21) at minimum necessary pressure to facilitate the movement of the yoke and assure the total retraction of the piston rod (24). Remove the pressure. This way the spring is fully extended.
 - 3.2.2 Remove the cover (2) from the center body by unscrewing all of the locking components: hex screw (18), hex head shoulder bolts (20) and eye bolts (13) plus upper nuts (12). Leave the studs (16) screwed into the center body (1).
 - 3.2.3 Hook and hold in tension the spring container using the specific lifting lug (54). Care should be taken to choose a lifting system suitable for the weight of the spring container. Refer to the weight table shown in Figures 3 and 4.
 - 3.2.4 Locate the studs (56) that connect the center body with the spring container. Carefully unscrew the nuts (59). Pull out the whole spring container.
- NOTE:** Take care to horizontally support the spring module during removal, so as not to damage the spring rod or the stud threads.
- 3.2.5 Before reassembling the new spring module to body, make sure stud threads are free of any dirt, shavings, or other debris. Clean threads with rag and solvent if required, and lubricate threads with an anti-seize compound.
 - 3.2.6 Assemble the new spring can, following the reverse procedure as described in points 3.2.4 to 3.2.1.
 - 3.2.7 Readjust the travel-stops, as instructed in paragraph 2.3.

3.3 Pneumatic Cylinder Maintenance

The pneumatic cylinder maintenance mainly consists in the replacement of all parts that may degrade in the course of time, even in the absence of faults. These components are the o-rings and the sliding elements of the piston.

The substitution of cylinder components (or of the whole cylinder) is not expected over the entire actuator life. However, accidental events may result in damage to these components. In these cases, proceed as described in the following steps.

There are two possible types of maintenance: standard maintenance which can be performed in the field without the need to remove the pneumatic cylinder from the actuator, and a more thorough one, following unexpected events, which often can be performed only after removing the cylinder from the actuator.

Standard In-field maintenance – perform the following steps:

The reference drawing is Figure 6.

▲ WARNING: Ensure that the pneumatic connection ports of the cylinder are disconnected. Also make sure that all pneumatic supplies to the control unit and all power supplies are disconnected. Finally, make sure that the actuator is in fail position, i.e., that it is not locked in a position with the spring compressed by means of locking devices.

- 3.3.1 Unscrew and remove the travel-stop of the pneumatic cylinder (28). For removing the stop, refer to the indications given in paragraph 2.3. If necessary, feed the pneumatic cylinder from the port on the head flange (21) at minimum necessary pressure to facilitate the movement of the yoke and assure the total retraction of the piston rod (24). In this way the spring is fully extended.
- 3.3.2 Remove at least two of the tie rods positioned on the upper part of the cylinder by unscrewing the nuts on the sides of the tail flange and of the head flange (or unscrewing the tie rods from the head flange if threaded into the flange.) This operation provides two free holes to be used for lifting the tail flange. Screw two (2) male eyebolts in these two holes and connect the tail flange to a lifting system. Care should be taken to choose a lifting system suitable for the weight of the cylinder. Refer to the weight table shown in Figures 3 and 4.
- 3.3.3 Remove all other tie rods (26), following the same procedure described in point 3.3.2. Then remove the tail flange (27) from the tube (22), being careful because it can have significant weight.
- 3.3.4 Finally, remove the tube (22). Take care not to scratch or dent the honed and plated inner surface of the tube.
- 3.3.5 Remove the o-rings (33) from the flanges, remove the o-ring of the piston (34) and finally the guide tapes (35) from the piston. Clean all surfaces of piston and flanges in contact with these components with rag and solvent. Brush the o-ring grooves with a light oil film and install the new o-rings. Spread a thin layer of grease on the bottom of the guide tape grooves and install the new guide tapes (35). Clean the internal surface of the tube (22) and lubricate with a protective oil film. Reassemble the parts of the cylinder with the reverse procedure as described in points 3.3.4 to 3.3.1. The tie rods should be tightened using a torque wrench, alternating between opposite holes, applying a torque according to Flowserve tables.
- 3.3.6 Readjust the stops as instructed in paragraph 2.3.

Extensive maintenance at the workshop, or for cylinder replacement

NOTE: The design of the LPS actuators permits the removal and replacement of all parts of the cylinder in the field. For the replacement of individual parts in the field, refer to specific instructions from Flowserve. The following indicates the procedure to remove/replace the complete cylinder.

▲ WARNING: Ensure that the pneumatic connection ports of the cylinder are disconnected. Also, make sure that all pneumatic supplies to the control unit and all power supplies are disconnected. Finally, make sure that the actuator is in fail position, i.e., that it is not locked in a position with the spring compressed by means of locking devices.

A – Double Acting Actuator. The reference drawing is Figure 6.

- 3.3.7 Sling the pneumatic cylinder in the horizontal position. Care should be taken to choose a lifting system suitable for the weight of the cylinder model. Refer to the weight tables shown in Figure 3 or 4.
- 3.3.8 Pressurize the cylinder and move the actuator to approximately 45°. Remove the pressure from the cylinder.
- 3.3.9 Remove the cover (2) from the center body by unscrewing all of the locking components: hex screw (18), hex head shoulder bolts (20) and eye bolts (13) plus upper nuts (12). Leave the studs (16) screwed into the center body (1).
- 3.3.10 Unscrew the set screw (68), holding in position the guide pin (65) of the adapter (58) and remove the guide pin itself. It shall then be possible to remove the cylinder, and the piston rod will be extracted along with the adapter (58).
- 3.3.11 Feed the pneumatic cylinder from the port on the head flange (21) at the minimum pressure necessary to totally retract the piston rod (24). The yoke will remain at 45°.
- 3.3.12 Locate the studs (56) that connect the center body to the cylinder. Carefully unscrew the nuts (59). Pull out the whole pneumatic cylinder.

NOTE: Take care during removal, so as not to damage the piston rod or the stud threads.

- 3.3.13 To reassemble the pneumatic cylinder complete with adapter, follow the reverse procedure as indicated in steps 3.3.12 to 3.3.9.
- 3.3.14 Readjust the stops as instructed in paragraph 2.3.

B – Single Acting Actuator. The reference drawing is Figure 5.

- 3.3.15 Sling the pneumatic cylinder in the horizontal position. Care should be taken to choose a lifting system suitable for the weight of the cylinder model. Refer to the weight tables shown in Figure 3 or 4.
- 3.3.16 Pressurize the cylinder from the pneumatic port on the end flange (27) at minimum necessary pressure to move the actuator to approximately 45°.
- 3.3.17 Measure the position of the spring can stopper (45), remove it, and then lock the spring in the compressed position by means of a special tool for this maintenance. The tool is to be installed in the opening where the spring-end travel-stop has been removed. Remove the pressure from the pneumatic cylinder.

▲ WARNING: At this point the spring is compressed and the spring module contains a large quantity of stored energy. Failure to properly engage the retaining device or failure to handle the spring carefully could result in release of the spring with potential damage to equipment or injury to personnel.

- 3.2.18 Unscrew and remove the stop of the pneumatic cylinder (28). To remove the stop, refer to paragraph 2.3. Feed the pneumatic cylinder from the port on the head flange (21) at minimum pressure necessary to totally retract the piston rod (24).
- 3.3.19 Remove the cover (2) from the center body by unscrewing all of the locking components: hex screw (18), hex head shoulder bolts (20) and eye bolts (13) plus upper nuts (12). Leave the studs (16) screwed into the center body (1).
- 3.3.20 Locate the studs (56) that connect the center body to the cylinder. With the yoke rotated of 45° it is possible to easily access these studs. Carefully unscrew the nuts (59). Pull out the whole pneumatic cylinder.

NOTE: Take care during removal, so as not to damage the piston rod or the stud threads.

- 3.3.21 After the substitution or extensive maintenance, reassemble the pneumatic cylinder complete with adapter, with the reverse procedure as described in step 3.3.20.

- 3.3.22 Reassemble the cover (2).
- 3.3.23 Slowly pressurize the pneumatic cylinder from the tail flange up to bring its stem in contact with the relevant guide block (5) slot.
- 3.3.24 Remove the special tool locking the spring can, so as to release the spring. The spring thrust is balanced by the thrust of the pressurized cylinder.
- 3.3.25 Depressurize the cylinder in order to bring the actuator in fail position.
- 3.3.26 Readjust the stops, as instructed in paragraph 2.3.

NOTE: If you are not in possession of the spring can locking tool to perform the removal of the cylinder, it is necessary to first remove the spring container.

3.4 Torque Module Maintenance

Standard maintenance of the center body may take place in the field, without the need to disassemble the spring container or the pneumatic cylinder. Perform the following steps. The reference drawing is Figure 5.

▲ WARNING: Ensure that the pneumatic connection ports of the cylinder are disconnected. Also make sure that all pneumatic supplies to the control unit and all power supplies are disconnected. Finally, make sure that the actuator is in fail position, i.e., that it is not locked in a position with the spring compressed by means of locking devices.

- 3.4.1 Remove the position indicators or other accessories, if fitted.
- 3.4.2 Remove the cover (2) from the center body by unscrewing all the locking components: hex screw (18), hex head shoulder bolts (20) and eye bolts (13) plus upper nuts (12). Leave the studs (16) screwed into the center body (1).
- 3.4.3 Remove the worn internal o-ring of the bushing (3) inserted in the cover (2). Clean the o-ring groove and the sliding area of the bushing and after having brushed these surfaces with a light oil film, install the new internal o-ring (14).
- 3.4.4 Apply a generous layer of grease on the sliding surfaces of the accessible moving parts inside the center body. In particular, grease the guide bar (7) and the surfaces of the slots of the wings of the yoke (4), in which the slider blocks (8) run. Reposition the cover, taking care to replace the cover gasket (11).

The design of LPS actuators features ease of on-site maintenance and an increased actuator life cycle. For this reason, appropriate procedures and equipment have been prepared, in order to allow the replacement of all parts of the center body without the need to disassemble the actuator from the valve. These instructions are part of a dedicated and separate procedure, available on request.

NOTE: Spring module and pressure module must be removed before disassembling the torque module.

NOTE: For the specific type and viscosity of grease to be used, refer to instructions packed with Flowserve replacement parts.

4 Field Conversion

Field Conversion From Fail CW to Fail CCW or Vice Versa (for Spring Return Actuators)

NOTE:

- The actuator designation needs to be suitably changed on the name plate.
- An additional adapter kit is required for field conversion from Fail CW to CCW and vice versa.

There are two different situations, requiring different sequences of instructions: in the first situation, the actuator is already disassembled from the valve. The second situation regards the conversion with the actuator assembled on the valve. The reference drawing is Figure 5.

THE ACTUATOR IS DISASSEMBLED FROM THE VALVE

▲ WARNING: Ensure that the pneumatic connection ports of the cylinder are disconnected. Also make sure that all pneumatic supplies to the control unit and all power supplies are disconnected. Finally, make sure that the actuator is in fail position, i.e., that it is not locked in a position with the spring compressed by means of locking devices.

- 4.1 Unscrew and remove the stop from the pneumatic cylinder (28). For removing the stop, refer to paragraph 2.3. If necessary, feed the pneumatic cylinder from the port on the head flange (21) at minimum necessary pressure to facilitate the movement of the yoke and assure the total retraction of the piston rod (24). Remove the pressure. In this way the spring is fully extended.
- 4.2 Remove the cover (2) from the center body by unscrewing all of the locking components: hex screw (18), hex head shoulder bolts (20) and eye bolts (13) plus upper nuts (12). Leave the studs (16) screwed into the center body (1).
- 4.3 Remove the spring can, carefully following the instructions given in paragraph 3.2.
- 4.4 Manually rotate the yoke (4) counterclockwise (or clockwise, depending on the original fail configuration) up to a position of approximately 45°.
- 4.5 Locate the studs (56) that connect the center body to the cylinder. With the yoke rotated of 45°, it is possible to easily access these studs. Carefully unscrew the nuts (59). Pull out the whole pneumatic cylinder (The stem is fully retracted).

NOTE: Take care during removal, so as not to damage the piston rod or the stud threads.

- 4.6 Change the adapter kit. Replace the adapters (57 and 58) designed for fail close (open) action, with the new ones designed for the opposite action. Take care to choose the adapter kit suitable for the yoke type in use (symmetric or canted).
- 4.7 Reassemble the pneumatic cylinder with adapter, using the reverse procedure as described in point 4.5.

- 4.8 Manually rotate the yoke (4) until the guide block (5) is in contact with the piston rod adapter (58), in correspondence of the relevant slot.
- 4.9 Reassemble the spring can, as instructed in paragraph 3.2.
- 4.10 Reposition the cover, taking care to replace the cover gasket (11).
- 4.11 Readjust the stops, as instructed in paragraph 2.3.
- 4.12 Periodically operate the actuator to check the functioning in the new fail configuration.

THE ACTUATOR IS CONNECTED TO THE VALVE (AND THE VALVE CAN BE STROKED)

NOTE: If the valve can not be rotated, due to the requirements of the plant, the actuator must be removed from the valve following the instructions given in paragraph 2.2. In this case, use the procedure described above. The actuator should be reinstalled in the same position of the valve.

▲ WARNING: Ensure that the pneumatic connection ports of the cylinder are disconnected. Also make sure that all pneumatic supplies to the control unit and all power supplies are disconnected. Finally, make sure that the actuator is in fail position, i.e., that it is not locked in a position with the spring compressed by means of locking devices.

- 4.13 Apply the minimum necessary pressure to the cylinder from the pneumatic port on the end flange and move the actuator to approximately 45°. If the actuator is provided with a manual override, you can use it to perform this operation.
- 4.14 Measure the position of the spring can stopper (45), remove it, and then lock the spring in the compressed position by means of a special tool for this maintenance. The tool is to be installed in the opening where the spring-end travel-stop has been removed. Remove pressure from the pneumatic cylinder.

▲ WARNING: At this point the spring is compressed and the spring module contains a large quantity of stored energy. Failure to properly engage the retaining device or failure to handle the spring carefully could result in release of the spring with potential damage to equipment or injury to personnel.

- 4.15 Unscrew and remove the travel-stop of the pneumatic cylinder (28). For removing the stop, refer to paragraph 2.3. Feed the pneumatic cylinder from the port on the head flange (21) at minimum necessary pressure up to totally retract the piston rod (24).
- 4.16 Remove the cover (2) from the center body by unscrewing all of the locking components: hex screw (18), hex head shoulder bolts (20) and eye bolts (13) plus upper nuts (12). Leave the studs (16) screwed into the center body (1).
- 4.17 Remove the spring can, carefully following the instructions given in paragraph 3.2.
- 4.18 Locate the studs (56) that connect the center body to the cylinder. With the yoke rotated of 45°, it is possible to easily access these studs. Carefully unscrew the nuts (59). Pull out the whole pneumatic cylinder. The stem has to be fully retracted.

NOTE: Take care during removal, so as not to damage the piston rod or the stud threads.

- 4.19 Change the adapter kit. Replace the adapters (57 and 58) designed for fail close (open) action, with the new ones designed for the opposite action. Take care to choose the adapter kit suitable for the yoke type in use (symmetric or canted).
- 4.20 Reassemble the spring can, as instructed in paragraph 3.2.
- 4.21 Reassemble the pneumatic cylinder with adapter, with the reverse procedure as described in point 4.18.

- 4.22 Apply the minimum pressure necessary to the pneumatic cylinder from the port on the end flange (27) until the piston rod moves the guide block (5) and partially compresses the spring. In this condition it will be possible to remove the special tool from the spring can.
- 4.23 Remove the pressure, checking that the actuator goes in the correct new fail position.
- 4.24 Reposition the cover, taking care to replace the cover gasket (11).
- 4.25 Readjust the travel-stops, as instructed in paragraph 2.3.

Figure 2 – Model Selection Table

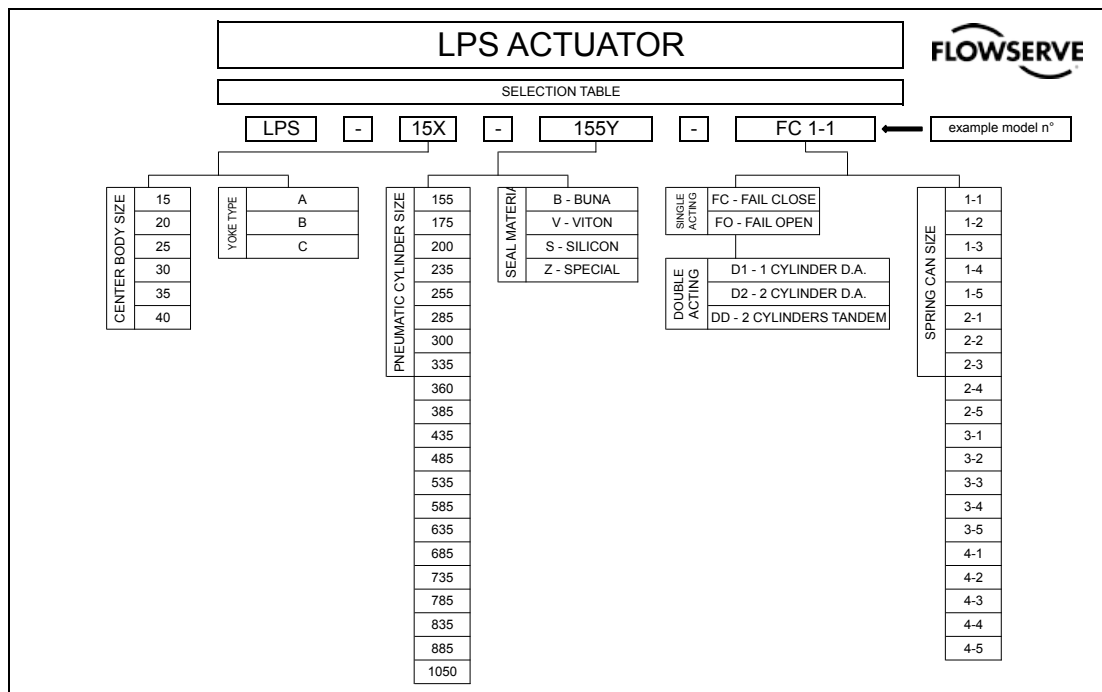

5 Disposal of Decommissioned Actuators

Actuators that are to be decommissioned permanently due to a plant closure or for another reason must have the stored energy in the spring neutralized. This can be done in several ways:

- 5.1 Decommissioning by filling with cement – following proper removal of the actuator from any hazardous areas, the spring module may be neutralized by cutting a small opening in the end or side of the spring can and filling the spring can with liquid cement and allowing the concrete to dry. This will eliminate any possibility of spring decompression if it were to be removed from the actuator without following proper procedures.
- 5.2 Decommissioning by cutting the spring – following proper removal of the actuator from any hazardous areas, the spring module may be neutralized by cutting a small opening in the side of the spring can and accessing the spring coils. The spring coils are then cut using a torch to relieve all compression and stored energy. Care should be taken that the opening in the spring can is sufficiently small to prevent any pieces of the spring from escaping when the spring is cut.

▲ WARNING: Failure to neutralize the spring in the actuator or to follow these instructions could lead to injury to personnel or property damage.

Either method is acceptable to Flowserve although the method outlined in 5.1 is preferred, as the stored energy in the spring is not suddenly released when the spring is cut. Hence, this is the safest method.

No actions need be taken on any other portions of the actuator to decommission it.

Figure 3 – Single Acting Actuator Weight Table

LPS ACTUATOR																																										
WEIGHT SELECTION TABLE - SINGLE ACTING VERSION - FAIL OPEN/CLOSE																																										
		LPS	-	15X	-	155Y	-	FC 1-1	←	example model n°																																
CENTER BODY SIZE	15			15	20	25	30	35	40																																	
	20			155	175	200	235	255	285	300	15	20	25	30	35	40																										
	25	30	35	40	335	360	385	435	485	535	585	635	685	735	785	835	885	1050	1-1	1-2	1-3	1-4	1-5	2-1	2-2	2-3	2-4	2-5	3-1	3-2	3-3	3-4	3-5	4-1	4-2	4-3	4-4	4-5				
	15	20	25	30	35	40	15	20	25	30	35	40	15	20	25	30	35	40	15	20	25	30	35	40	15	20	25	30	35	40	15	20	25	30	35	40	15	20	25	30	35	40
	15	20	25	30	35	40	15	20	25	30	35	40	15	20	25	30	35	40	15	20	25	30	35	40	15	20	25	30	35	40	15	20	25	30	35	40	15	20	25	30	35	40
	15	20	25	30	35	40	15	20	25	30	35	40	15	20	25	30	35	40	15	20	25	30	35	40	15	20	25	30	35	40	15	20	25	30	35	40	15	20	25	30	35	40

weights in kg (lbs)

Weights may be subject to changes over time. For the accurate measurement please contact the manufacturer.

PNEUMATIC CYLINDER SIZE

SPRING CAN SIZE

Figure 4 – Double Acting Actuator Weight Table

LPS ACTUATOR																								
WEIGHT SELECTION TABLE - DOUBLE ACTING VERSION																								
		LPS	-	15X	-	155Y	-	D1	←	example model n°														
CENTER BODY SIZE	15			15	20	25	30	35	40															
	20			155	175	200	235	255	285	300	15	20	25	30	35	40								
	25	30	35	40	335	360	385	435	485	535	585	635	685	735	785	835	885	1050	D1					
	15	20	25	30	35	40	15	20	25	30	35	40	15	20	25	30	35	40	15	20	25	30	35	40
	15	20	25	30	35	40	15	20	25	30	35	40	15	20	25	30	35	40	15	20	25	30	35	40
	15	20	25	30	35	40	15	20	25	30	35	40	15	20	25	30	35	40	15	20	25	30	35	40

weights in kg (lbs)

Weights may be subject to changes over time. For the accurate measurement please contact the manufacturer.

PNEUMATIC CYLINDER SIZE

Figure 6 – Double Acting Actuator Exploded View

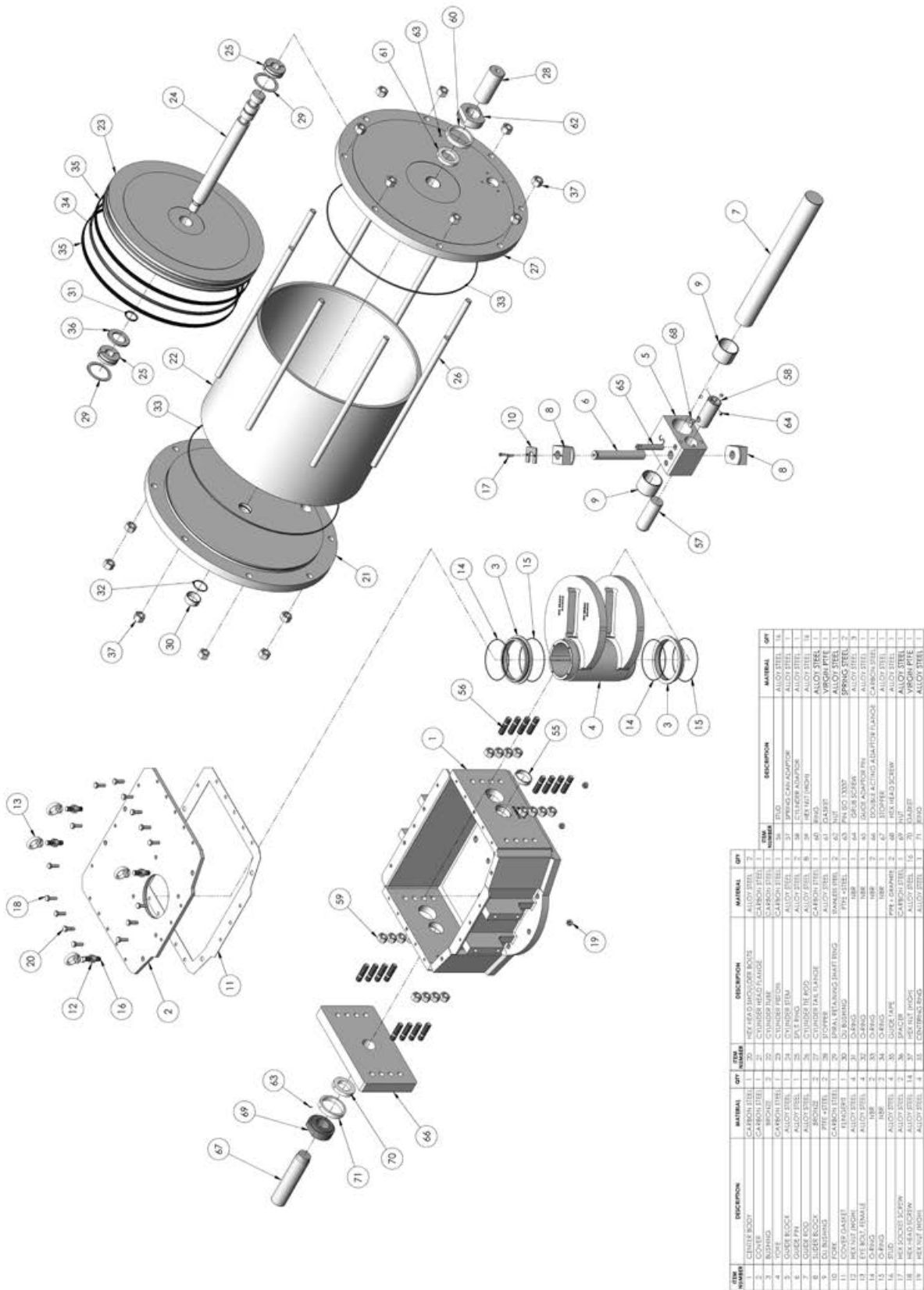

ITEM NUMBER	DESCRIPTION	MATERIAL	QTY	ITEM NUMBER	DESCRIPTION	MATERIAL	QTY
1	ACTUATOR BODY	ALLOY STEEL	1	23	SEAL RING	ALLOY STEEL	2
2	COVER	ALLOY STEEL	1	24	SEAL RING	ALLOY STEEL	2
3	SEAL RING	ALLOY STEEL	2	25	SEAL RING	ALLOY STEEL	2
4	SEAL RING	ALLOY STEEL	2	26	SEAL RING	ALLOY STEEL	2
5	SEAL RING	ALLOY STEEL	2	27	SEAL RING	ALLOY STEEL	2
6	SEAL RING	ALLOY STEEL	2	28	SEAL RING	ALLOY STEEL	2
7	SEAL RING	ALLOY STEEL	2	29	SEAL RING	ALLOY STEEL	2
8	SEAL RING	ALLOY STEEL	2	30	SEAL RING	ALLOY STEEL	2
9	SEAL RING	ALLOY STEEL	2	31	SEAL RING	ALLOY STEEL	2
10	SEAL RING	ALLOY STEEL	2	32	SEAL RING	ALLOY STEEL	2
11	SEAL RING	ALLOY STEEL	2	33	SEAL RING	ALLOY STEEL	2
12	SEAL RING	ALLOY STEEL	2	34	SEAL RING	ALLOY STEEL	2
13	SEAL RING	ALLOY STEEL	2	35	SEAL RING	ALLOY STEEL	2
14	SEAL RING	ALLOY STEEL	2	36	SEAL RING	ALLOY STEEL	2
15	SEAL RING	ALLOY STEEL	2	37	SEAL RING	ALLOY STEEL	2
16	SEAL RING	ALLOY STEEL	2	38	SEAL RING	ALLOY STEEL	2
17	SEAL RING	ALLOY STEEL	2	39	SEAL RING	ALLOY STEEL	2
18	SEAL RING	ALLOY STEEL	2	40	SEAL RING	ALLOY STEEL	2
19	SEAL RING	ALLOY STEEL	2	41	SEAL RING	ALLOY STEEL	2
20	SEAL RING	ALLOY STEEL	2	42	SEAL RING	ALLOY STEEL	2
21	SEAL RING	ALLOY STEEL	2	43	SEAL RING	ALLOY STEEL	2
22	SEAL RING	ALLOY STEEL	2	44	SEAL RING	ALLOY STEEL	2
23	SEAL RING	ALLOY STEEL	2	45	SEAL RING	ALLOY STEEL	2
24	SEAL RING	ALLOY STEEL	2	46	SEAL RING	ALLOY STEEL	2
25	SEAL RING	ALLOY STEEL	2	47	SEAL RING	ALLOY STEEL	2
26	SEAL RING	ALLOY STEEL	2	48	SEAL RING	ALLOY STEEL	2
27	SEAL RING	ALLOY STEEL	2	49	SEAL RING	ALLOY STEEL	2
28	SEAL RING	ALLOY STEEL	2	50	SEAL RING	ALLOY STEEL	2
29	SEAL RING	ALLOY STEEL	2	51	SEAL RING	ALLOY STEEL	2
30	SEAL RING	ALLOY STEEL	2	52	SEAL RING	ALLOY STEEL	2
31	SEAL RING	ALLOY STEEL	2	53	SEAL RING	ALLOY STEEL	2
32	SEAL RING	ALLOY STEEL	2	54	SEAL RING	ALLOY STEEL	2
33	SEAL RING	ALLOY STEEL	2	55	SEAL RING	ALLOY STEEL	2
34	SEAL RING	ALLOY STEEL	2	56	SEAL RING	ALLOY STEEL	2
35	SEAL RING	ALLOY STEEL	2	57	SEAL RING	ALLOY STEEL	2
36	SEAL RING	ALLOY STEEL	2	58	SEAL RING	ALLOY STEEL	2
37	SEAL RING	ALLOY STEEL	2	59	SEAL RING	ALLOY STEEL	2
38	SEAL RING	ALLOY STEEL	2	60	SEAL RING	ALLOY STEEL	2
39	SEAL RING	ALLOY STEEL	2	61	SEAL RING	ALLOY STEEL	2
40	SEAL RING	ALLOY STEEL	2	62	SEAL RING	ALLOY STEEL	2
41	SEAL RING	ALLOY STEEL	2	63	SEAL RING	ALLOY STEEL	2
42	SEAL RING	ALLOY STEEL	2	64	SEAL RING	ALLOY STEEL	2
43	SEAL RING	ALLOY STEEL	2	65	SEAL RING	ALLOY STEEL	2
44	SEAL RING	ALLOY STEEL	2	66	SEAL RING	ALLOY STEEL	2
45	SEAL RING	ALLOY STEEL	2	67	SEAL RING	ALLOY STEEL	2
46	SEAL RING	ALLOY STEEL	2	68	SEAL RING	ALLOY STEEL	2
47	SEAL RING	ALLOY STEEL	2	69	SEAL RING	ALLOY STEEL	2
48	SEAL RING	ALLOY STEEL	2	70	SEAL RING	ALLOY STEEL	2
49	SEAL RING	ALLOY STEEL	2	71	SEAL RING	ALLOY STEEL	2



**Flowserve Limitorque
Fluid-Power Product Sales**

via Rio Vallone 17
20883 Mezzago MB
Italy
Fax: +39 039 62060 213
Phone: +39 620 601 200
Email: limitorque@flowserve.com

**Flowserve Limitorque
Fluid-Power Product
Manufacturing and Operations**

via Rio Vallone 17
20883 Mezzago MB
Italy
Fax: +39 039 62060 213
Phone: +39 620 601 200
Email: limitorque@flowserve.com

**Flowserve Limitorque
Fluid-Power Product
Research and Development**

Viale dell'Artigianato, 24
29122 Piacenza, PC
Italy
Email: limitorque@flowserve.com

**To find your local Flowserve representative,
visit www.flowserve.com or call:
USA +1 800 225 6989
International +1 972 910 0774**

FCD LFENIM0001-00 (E/A4) 12/13 © 2013 Flowserve Corporation.

Flowserve Corporation has established industry leadership in the design and manufacture of its products. When properly selected, this Flowserve product is designed to perform its intended function safely during its useful life. However, the purchaser or user of Flowserve products should be aware that Flowserve products might be used in numerous applications under a wide variety of industrial service conditions. Although Flowserve can (and often does) provide general guidelines, it cannot provide specific data and warnings for all possible applications. The purchaser/user must therefore assume the ultimate responsibility for the proper sizing and selection, installation, operation, and maintenance of Flowserve products. The purchaser/user should read and understand the Installation Operation Maintenance (IOM) instructions included with the product, and train its employees and contractors in the safe use of Flowserve products in connection with the specific application.

While the information and specifications contained in this literature are believed to be accurate, they are supplied for informative purposes only and should not be considered certified or as a guarantee of satisfactory results by reliance thereon. Nothing contained herein is to be construed as a warranty or guarantee, express or implied, regarding any matter with respect to this product. Because Flowserve is continually improving and upgrading its product design, the specifications, dimensions and information contained herein are subject to change without notice. Should any question arise concerning these provisions, the purchaser/user should contact Flowserve Corporation at any one of its worldwide operations or offices.

© 2013 Flowserve Corporation, Irving, Texas, USA. Flowserve is a registered trademark of Flowserve Corporation.